

# The G5IJ An

**D**uring the time that I have been compiling the 'Newcomers' News' column there have been several items that have brought significant responses and requests for further information. However, the feedback from my mention of the G5IJ antenna in the August column [1] attracted so much attention that we have had to dedicate a whole article to it!

Ivan James, G5IJ, first aired his design through the pages of *RadCom* in 1996 [2] and described it as a 'push-pull fed folded mono-pole'. Pat Hawker, G3VA, was at first unconvinced by the design but modified his views after trying one.

The antenna was featured again in *Practical Wireless* in 2000 [3] where it was advocated as a multi-band antenna. It was also suggested that the 20m feeder could be replaced by a dipole or even a loop.

A search on the Internet brought few further references. One site that does mention the antenna is that of the Raynet HF team (see 'Websearch'), members of which have experimented with the G5IJ for near vertical incidence (NVIS) propagation. This reference includes radiation patterns modelled using the *NEC2* computer software, but unfortunately there are no reports on the results of their practical tests.

## CONSTRUCTION

The antenna consists of a 20m length of 300K feeder fed via a transformer so that both feeder conductors are fed in phase with no RF earth (see **Fig 1**). Details of the toroidal transformer are given in **Fig 2**.

Constructional details have been provided by Ken Sharples, M5KEN (see **Fig 3**). The only tricky bit is making the toroidal transformer. There are five steps: 1. Fold the 20SWG enamel coated wire in half and twist into a 'bifilar' winding, so that there is a small 'loop' at one end and two open wires at the other end. 2. Wind this 27 times on to the T200 core. 3. Tease out the braid of the coax 1.3m from the end and solder it to the 'loop' of the bifilar winding. 4. Wind the coax over the bifilar windings, taking care to wind it in the same direction. 5. After winding the coax to cover the bifilar winding, bare the end of the coax and cut off the braid. Solder the inner of the coax to

the 'loop'. Thus, the loop at the end of the bifilar winding, the *inner* at the end of the coax, and the *braid* of the coax at a point 1.3m from its end, are all soldered together.

## SOME DOUBTS

I really became aware of the G5IJ antenna through the pages of *Hot Iron*, a constructors' newsletter produced by Tim Walford, G3PCJ [4]. Tim had some doubts about feeding two conductors in phase and sought the views of his "antenna guru", Eric, G3GC, who shared Tim's scepticism. There was even some thought of the antenna being an elaborate April fool joke!

Andrew Howlett, G1HBE, was one of the first to air his views after the mention in 'Newcomers' News'. He said he couldn't understand what all the fuss is about. "The transformer is simply a matching device between the 50K coax feeder and the high impedance of the 20m wire (a half-wave on 7MHz) . . . this antenna design introduces nothing new, and seems to try to befuddle novices with a complicated-looking transformer".

"You might as well have connected a random length of wire to your ATU", Dave Buddery, G3OEP, was told by his son, G3SEP. However, Dave's 40m loop, which will not load up on 3.5MHz, appears to work perfectly well when fed via a G5IJ transformer. Dave stresses that the toroid *must* be of a suitable material. He suspects the lower frequency rings used in TV circuits would be too lossy and heat would soon build up.

A discussion I had with 'learned colleagues' from the Radiocommunications Agency and the RSGB came to the conclusion that losses in the transformer were probably the reason for the multi-band capability. We decided that whilst this may be a useful feature it would not be very efficient.

It seems that the G5IJ antenna attracts much scepticism, especially amongst those who haven't tried one!

## SUCCESSFUL USE

Roy Walker, G0TAK / 2E1RAF, the author of the *PW* article mentioned above, wrote to add some positive input to the debate. He reports that since he read the original *RadCom* article in 1996 the G5IJ, in various forms, has been his main station antenna and that he has also used one at portable locations throughout England, Scotland and Wales.

In 1999 he used the aerial in qualifying for the Arkansas QRP Club Millennium Award by making in excess of 2000 CW contacts with 5 watts (in five months). In 2000 he

entered the G-QRP Millennium Award scheme and was placed third in the world and top UK station all with the G5IJ and 5W of Morse code.

The present G5IJ aerial configuration at Roy's QTH is a low horizontal loop of about 80m of very thin wire. The loop is suspended on the garden fence and the dry stone wall at the bottom of the garden at a height of 1m. This has allowed contact with the USA on 5 watts, so it must be working at least to some extent.

Roy asks that I correct one point from the August 2003 'Newcomers' News'. I quoted him as saying that "the aerial has a low feed-point impedance on all bands". What he actually said was that "it will tune on all the bands from 1.8MHz to 433MHz . . . the matching on all the bands is reasonably flat, though it may be a little higher than you would expect". Nevertheless, he is still of the opinion that the aerial is a good compromise and enables newly-qualified amateurs to operate on all HF bands with minimum expense.

Licensed in 1951, Guy Moser, G3HMR, has enjoyed a variety of antennas and equipment. He tried a G5IJ antenna and found it to be "OK", but no more. He now uses the transformer to drive 200ft of speaker wire, looped around his garden at an average height of 2m. He has 88 QSOs logged with this antenna, mainly on 7 and 10MHz CW. He finds his 12AVQ vertical better for 14 and 21MHz.

Ron Smith, M1DEG, made a G5IJ antenna soon after it was featured in *Practical Wireless*. He had just bought a Hustler three-band vertical antenna but found the G5IJ better in all respects. He is limited in choice as his back yard is just 8m by 3m, more or less at sea level - so I guess the G5IJ is bent to fit the space available. With 10W and his Foundation callsign, M3AJU, Ron has contacted stations across Europe and east coast USA. At the time he wrote, just before the Morse requirement was lifted, he was anxious to try the G5IJ using his original callsign and 100W.

## EASY CONSTRUCTION

Adrian Norcross, M1ZRP / M3ANR, of the Chorley Amateur Radio Club, found that constructing the G5IJ was reasonably easy and was a good learning experience in the art of winding toroids. He purchased the toroidal transformer core, and some 20SWG enamelled copper wire from Sycom in Surrey [5], who he says were "very helpful". He normally uses the antenna in a horizontal-V configuration and this has brought many contacts on 14MHz including UA9CDC, RN3BZ,

## REFERENCE

- [1] 'Newcomers' News', G0FUW, *RadCom*, August 2003, p53.
- [2] 'Technical Topics', G3VA, *RadCom*, March 1996, pp69-71.
- [3] 'Antenna Workshop', G0TAK, *Practical Wireless*, August 2002, p39.
- [4] *Hot Iron*, G3PCJ, Summer 2003, Issue 40.
- [5] Sycom, PO Box 148, Leatherhead, Surrey KT22 9YW.

W E B S E A R C H



Raynet HF Team:

[www.raynet-hf.net/HFANTENNA.html](http://www.raynet-hf.net/HFANTENNA.html)

# tenna

G4VFU/MM (off the coast of Tripoli), FY5GS, 4X4BO, WA2VUY and K2LEI to list but a few. He has also had a few inter-G (UK) contacts on 7MHz.

Adrian reports that in this configuration the antenna needs a little tuning on 7MHz and 14MHz but it is fine without an Antenna Tuning Unit (ATU) as you move higher up the bands, 21MHz having a very low VSWR. A balanced-to-unbalanced transformer (balun) is employed on the coax feeder as Adrian detected some RF on the ATU and rig casings. Since incorporating the coaxial balun as part of the feeder the problem has gone away.

Kevin Murphy, G4XBG, his wife, 2E1CCI, and their two dogs had a week's break in the Radnorshire hills (just into Wales). They stayed at a cottage in a steep-sided valley, which was only good for HF. There was a long garden with a number of trees, so a simple wire aerial would not be a problem.

Kevin remembered seeing the G5IJ design and thought it might be just the job for the cottage. The only thing he had to obtain was the ferrite ring, which he also bought from Robin Sykes at Sycom for £4. To keep things as simple as possible he strapped the two outputs together and tested it at home with a short length (20ft) of wire on the end. Received signal strengths were quite good considering its dimensions. The antenna tuned up on all the HF bands and at 100 watts there was no sign of the transformer windings getting hot. Kevin muses "it must work as a broad band transformer but I can't explain it".

Some 40m of plastic coated wire were attached to the transformer in this 'long wire' configuration for the /P operation. Strung up in the trees at about 20ft above ground it gave reasonable results for inter-G working on 3.5MHz and on topband (1.8MHz). On 7 and 14MHz strong European stations were worked and Kevin even worked the west coast of USA on 21MHz. He was very pleased with the results, and has recently used the same set-up from a narrow boat when moored up, by throwing the wire up into trees along the bank. He finds that it requires an ATU to match to the rig, and whilst it may not be the most efficient antenna, it clearly gets results.

## SOME TEST RESULTS

Inspired by the *PW* article, Rob Gibson, G0UOO, built one of these antennas last September. In use it showed a "low-ish" VSWR (better than 3:1) across the HF bands and produced plenty of reasonable reports on the air. However, it seemed generally inferior to his 66ft doublet, so he put it to one side.

After seeing the piece in 'Newcomers' News' he got to thinking about the G5IJ antenna again, and how it could have such a flat VSWR across such a wide range of frequencies. Suspecting that this may be due to losses in the toroidal transformer, he dug out his previous construction and tried an experiment. Rob disconnected the antenna element from the transformer, leaving about 5cm of wire on the antenna side, and ran an SWR check across the HF bands. This showed a 5:1 VSWR on 3.5MHz, and better than 3:1 on most of the higher bands. Indeed, it showed nearly 1:1 on 18 and 21MHz!

Rob is another who believes that the G5IJ's broad bandwidth may be due to losses in the toroidal transformer. Anyway, just in case he'd done something wrong when winding the transformer, he made up two more and these gave very similar results to the first. Rob wonders just how much power is wasted in the transformer and concludes, "the antenna will produce contacts, but I feel that other designs, such as a doublet, are much more efficient". Of course, the exact power loss question could be answered by measuring the power through two transformers connected back-to-back (has anyone tried this?)

Terry Steeper, G7JFI, of the Lincoln Short Wave Club (G5FZ, G6COL), made an antenna with a toroid of the right size, but the wrong material - the toroid was intended for 50Hz use! However, with just a single 18ft wire radiating element, it proved useful on 7MHz and above, providing a match of between 1.5:1 and 3:1 depending on the band. Spurred on by this early success, Terry and his friend Brian Matthews, M3DMV, constructed a better version, using a T225-2 toroid and around 60ft of wire, doubled as in the original design. Brian is very pleased with its performance and has worked the USA on 14MHz and 10 watts.

A 'card' full of the toroids was purchased from Power Magnetics, and these were all snapped up by the club members in one evening! Apart from one member who claimed, "it nearly blew my rig up!", everyone seems to have had some success with the G5IJ antenna. However, Terry reports that he did experience some breakthrough on TV when using the antenna without ATU or earth.

All in all, Terry concludes that it is an interesting design, simple to make, and it got a few LSWC members constructing, so it was a success from many viewpoints.

## CONCLUSION

Based on the feedback I have received, I have to conclude that the G5IJ antenna appears to be a viable radiator but I think Ken Sharples, M5KEN, sums it up very well. "This antenna follows the usual rules, the higher the better, but it is very forgiving for the small back yard plot. It is no DX buster of course, but it is a good start-up antenna that is cheap and easy to make". ♦

**Fig 1: General arrangement of the G5IJ antenna.**

**Fig 2: Winding details of toroidal transformer BM3 as shown in Fig 1.**

**Fig 3: Constructional details as provided by Ken Sharples, M5KEN. 1. Amadon T200-2 core. 2. 5m of 20SWG enamel coated copper wire (secondary). 3. 50K (thin) coax, length to suit. 4. 20m bell wire. 5. 2-port terminal block. 6. PL259 coaxial plug.**

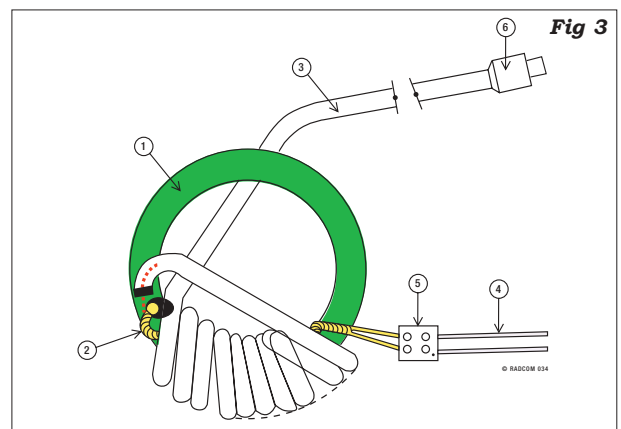
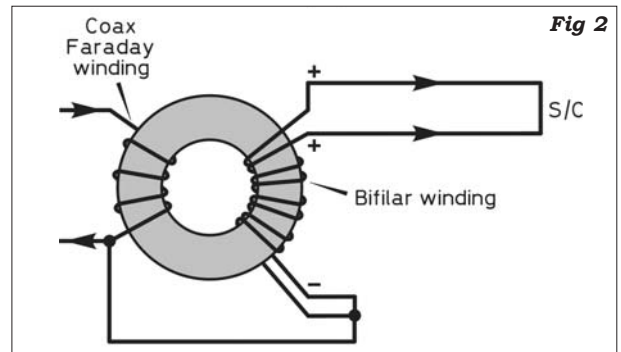
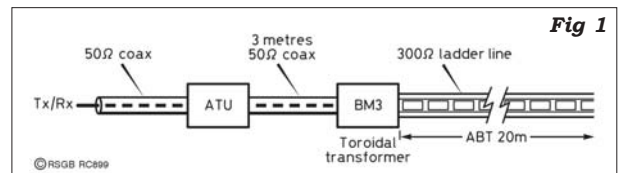

# Revisited